

Thermo Pride®

OIL FIRED FURNACE

INSTALLATION AND OPERATION MANUAL WITH USERS INFORMATION SECTION

MODELS:

OC2-56

OC5-85

OT5-85

OT11-105

OT16-125

OL2-56

OL5-85

OL11-105

OL16-125

OL20-151

OL33-200

OL37-250

OL39-320

OH5-85

OH11-105

OH16-125

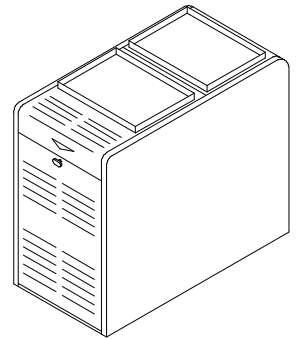
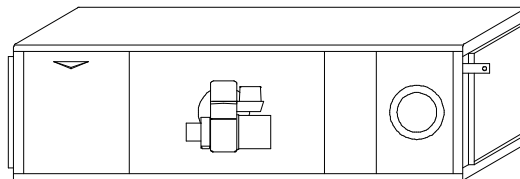
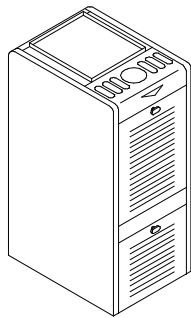
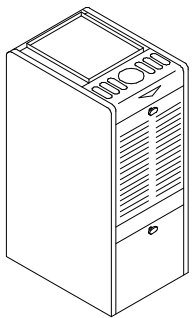

⚠ WARNING: IF THE INFORMATION IN THESE INSTRUCTIONS IS NOT FOLLOWED EXACTLY, A FIRE OR EXPLOSION MAY RESULT CAUSING PROPERTY DAMAGE, PERSONAL INJURY, OR LOSS OF LIFE.

DO NOT STORE OR USE GASOLINE OR OTHER FLAMMABLE VAPORS AND LIQUIDS IN THE VICINITY OF THIS OR ANY OTHER APPLIANCE.

⚠ WARNING: IMPROPER INSTALLATION, ADJUSTMENT, ALTERATION, SERVICE, OR MAINTENANCE CAN CAUSE INJURY OR PROPERTY DAMAGE. REFER TO THIS MANUAL. FOR ASSISTANCE OR ADDITIONAL INFORMATION CONSULT A QUALIFIED INSTALLER, OR SERVICE AGENCY.

PLEASE READ THESE INSTRUCTIONS PRIOR TO INSTALLATION, INITIAL FIRING, AND BEFORE PERFORMING ANY SERVICE OR MAINTENANCE. THESE INSTRUCTIONS MUST BE LEFT WITH THE USER AND SHOULD BE RETAINED FOR FUTURE REFERENCE BY QUALIFIED SERVICE PERSONNEL.



THERMO PRODUCTS, LLC.
PO BOX 237
DENTON, NC 27239
PHONE: 800-476-4328



MADE IN USA

MO-100G
ECN 5634-MA 200417

I. SAFETY SECTION

This page contains various warnings and cautions found throughout the Oil Furnace Manual. Please read and comply with the statements below.

△WARNING AND CAUTIONS:

△WARNING: This furnace is not to be used as a construction heater. See Page 1.

△ CAUTION MUST BE TAKEN NOT TO EXCEED 90° ROTATION (OF THE FLUE ELBOW) COUNTERCLOCKWISE FROM THE VERTICAL POSITION. See Page 2.

△WARNING: When cutting openings in the casing **DO NOT CUT ANY SUPPORTING CLIPS OR ANGLES.** See Page 5.

△WARNING: The predetermined fan and limit locations on all of the Thermo Pride oil fired furnaces have been tested and approved by Thermo Products, LLC. in conjunction with Underwriters Laboratories, Inc. Any attempt to relocate these safety controls or replace these safety controls with a control that is not approved, or is incompatible, may result in personal injury, substantial property damage or death. See Page 6.

△WARNING: THE HEAT EXCHANGER MUST BE CLEANED BY A QUALIFIED SERVICE PERSON. See Page 11.

△CAUTION: DO NOT ATTEMPT TO MAKE REPAIRS YOURSELF! See Page 13.

△WARNING: The area around the furnace should be kept free and clear of combustible liquids and material, especially papers and rags. See Page 13.

△WARNING: NEVER burn garbage or refuse in your furnace. Never try to ignite oil by tossing burning papers or other material into your furnace. See Page 13.

△WARNING: Thermo Products oil furnaces are designed to burn No. 1 or No. 2 distillate fuel oil. **NEVER USE GASOLINE OR A MIXTURE OF OIL AND GASOLINE.** See Page 13.

△CAUTION: DO NOT ATTEMPT TO START THE BURNER WHEN:

1. Excess oil has accumulated,
2. The furnace is full of vapors
3. The combustion chamber is very hot.

IF ONE OR MORE OF THESE CONDITIONS EXIST, CONTACT A QUALIFIED SERVICE PERSON. See Page 13.

All installations and services must be performed by qualified service personnel.

This page contains reproductions of the various instruction and warning labels placed on the Thermo Pride Oil Furnaces. Please read and comply with the contents of these labels.



**Underwriters
Laboratories Inc.**
LISTED



**EFFICIENCY
RATING
CERTIFIED
GAMA**

OIL-FIRED FURNACE NO. MODEL

FOR USE WITH INTEGRAL GROUP PRIMARY SAFETY CONTROLS.
OIL NOT HEAVIER THAN NO. 2

INPUT BTU/HR INPUT G.P.H. PUMP PRESSURE P.S.I. 115 V 60 HZ

TOTAL CURRENT AMPS
MINIMUM CIRCUIT CAPACITY
MAXIMUM FUSE SIZE
EXTERNAL STATIC PRESSURE (IN. W.C.)
MAXIMUM DESIGNED OUTLET AIR TEMPERATURE 200° F OR LESS.
MAY BE INSTALLED WITH CLEARANCES TO UNPROTECTED
COMBUSTIBLE MATERIAL NOT LESS THAN:

(INCHES)

FOR MAXIMUM EFFICIENCY (AFUE) SET BURNER COMBUSTION FOR 12% CO₂ MINIMUM AND
FURNACE TEMPERATURE RISE FOR 70°F MAXIMUM.

Thermo Products P.O. BOX 217 - NORTH JUDSON, IN 45366

390055
390052



WARNING: This product can expose you to chemicals, including Chromium, which are known to the state of California to cause cancer and birth defects or other reproductive harm. For more information go to www.P65Warnings.ca.gov.



AVERTISSEMENT: Ce produit peut vous exposer à des produits chimiques, y compris le chrome, qui sont connus dans l'état de Californie pour causer le cancer et des malformations congénitales ou d'autres problèmes de reproduction. Pour plus d'informations, visitez www.P65Warnings.ca.gov.

390341

THIS PANEL REMOVABLE BY QUALIFIED SERVICE PERSONNEL FOR ACCESS TO HEAT EXCHANGER CLEAN OUTS. BE CERTAIN CLEAN OUT GASKETS ARE INTACT AND THE COVERS IN PROPER POSITION TO ENSURE A COMPLETE SEAL PRIOR TO OPERATION.

390005

SHOULD THIS UNIT BE DISASSEMBLED ALL COMPONENTS, PANELS, BLOCK OFFS, COLLARS, GASKETS, AND FASTENERS MUST BE REASSEMBLED AS ORIGINALLY FACTORY PRODUCED.

390056

OUTSIDE POWER SOURCE
115 V. 60 CYCLE TO BE CONNECTED TO WIRES INSIDE THIS BOX.
CONNECT WIRE #1 TO THE "HOT" LINE.
CONNECT WIRE #2 TO THE "COMMON" LINE.

390004

"DANGER— TO AVOID INJURY FROM MOVING PARTS SHUT OFF THE FURNACE BEFORE REMOVING THIS DOOR."

WHEN IT BECOMES NECESSARY TO REPLACE OR WASH FILTER, REMOVE THE DIRTY FILTER FROM THE RACKS PROVIDED AND WASH OR REPLACE WITH IDENTICAL NEW FILTERS.

THE BLOWER MOTOR LOCATED BEHIND THIS DOOR MAY OR MAY NOT REQUIRE LUBRICATION. IF LUBRICATION INSTRUCTIONS ARE NOT SHOWN ON THE MOTOR NAME PLATE THE MOTOR SHOULD NOT BE LUBRICATED. IF THE NAME PLATE INDICATES THAT THE MOTOR REQUIRES LUBRICATION, LUBRICATE THE MOTOR AS DIRECTED OR USE 30 DROPS OF SAE 20 WEIGHT OIL OR EQUIVALENT TWICE A YEAR. DO NOT USE A LIGHT HOUSEHOLD GRADE OIL.

390025

WARNING: THIS UNIT MUST BE INSTALLED AND SERVICED BY A QUALIFIED CONTRACTOR ONLY.

390057



WARNING

The following items should be inspected every year by a qualified heating contractor. Correct any deficiencies at once.

Heat Exchanger: Inspect for corrosion, pitting, warpage, deterioration, carbon build up and loose gaskets.

Burner: Check for correct operation, proper combustion, no fuel leakage, and if provided, clean burner filter.

Chimney/Vent Pipe: Inspect for restriction, loose joints, abnormal carbon build up and condensation.

Controls: Check for correct operation and proper settings, (if manually adjustable).

Periodic visual inspections should also be made by the owner during the heating season. Call a qualified heating contractor to report suspected deficiencies. (Do not attempt to make repairs yourself!)

Further owner and heating contractor responsibilities are detailed in the installation and maintenance instruction manual. (Shut off power before inspecting.)

390399

All installations and services must be performed by qualified service personnel.

TABLE OF CONTENTS

<u>SECTION</u>		<u>BEGINNING</u>
<u>PAGE</u>		
I. SAFETY SECTION		i
II. GENERAL INSTRUCTIONS		1
A. DRAFT REGULATORS		3
B. DUCT WORK/AIR CONDITIONING		3
C. FILTERS MOUNTED EXTERNAL TO FURNACE		4
D. FAN AND LIMIT POSITION AND LOCATION		6
E. BURNER INSTALLATION		6
F. HORIZONTAL FURNACE POSITIONS		8
G. EXTERNAL WIRE HARNESS LOCATIONS		8
H. BURNER SPECIFICATIONS AND APPLICATIONS		9
I. HEAT EXCHANGER CLEANING INSTRUCTIONS		11
III. USERS INFORMATION SECTION		12
A. OIL SUPPLY		12
B. COMBUSTION AIR SUPPLY		12
C. INSPECTION AREAS		13
D. STARTING THE BURNER		13
E. FILTER CLEANING AND LOCATIONS		13
APPENDIX – A	REPLACEMENT PARTS LIST	16
APPENDIX – B	WIRING DIAGRAMS	26

All installations and services must be performed by qualified service personnel.

II. GENERAL INSTRUCTIONS - READ BEFORE START OF INSTALLATION

1. The heating output capacity of the furnace proposed for installation should be based on a heat loss calculation made according to the manuals provided by the Air Conditioning Contractors of America (ACCA) or the American Society of Heating, Refrigeration and Air Conditioning Engineers, Inc. (ASHRAE).
2. All local codes and/or regulations take precedence over the instructions in this manual and should be followed accordingly. In the absence of local codes, installation must conform with these instructions and regulations of the National Fire Protection Association, and to the provisions of the National Electrical Code (ANSI/NFPA 70-1999 or latest edition).
3. The installed furnace must be level and positioned in a central location with respect to outlet registers. It should be located near the chimney to minimize any horizontal run of flue pipe, which may be required.
4. A furnace installed in a residential garage must be installed so the burner and ignition source are located higher than 18 inches above the floor, unless the required combustion air is taken from the exterior of the garage. Also, the furnace must be located or protected to avoid physical damage by vehicles.

⚠WARNING: This furnace is not to be used as a construction heater.

5. Listed below are definitions of "COMBUSTIBLE MATERIAL" and "NON-COMBUSTIBLE MATERIAL."

COMBUSTIBLE MATERIAL:

Material made of or surfaced with wood, compressed paper, plant fibers, plastics, or other material that will ignite and burn, whether flame resistant or not.

NON-COMBUSTIBLE MATERIAL:

Material that is not capable of being ignited and burned. Such materials consist entirely of, or a combination of, steel, iron, brick, tile, concrete, slate, or glass.

MINIMUM CLEARANCES TO COMBUSTIBLE MATERIALS

TYPE OF UNIT	MODEL NO. ¹	FROM SIDES OF FURNACE		FRONT	TOP & SIDES OF PLENUM	FROM THE FLUE/VENT	REAR
LOWBOYS	OL2	1"		2"	1"	4"	1"
	OL5,11,16	1"		24"	1"	6"	1"
	OL20	1"		24"	1"	18"	1"
	OL33,37,39	1"		24"	1"	18"	1"
HIGHBOYS	OH11	1"		24"	1"	9"	1"
	OH5	1"		24"	1"	6"	1"
	OH16	1"		24"	1"	9"	1"
COUNTERFLOWS	OC2	1"		4"	1"	6"	1"
	OC5	1"		4"	1"	9"	1"
TYPE OF UNIT	MODEL NO. ¹	FRONT	TOP	REAR	BOTTOM	FROM THE FLUE/VENT	ANY SIDE OF PLENUM
HORIZONTALS ²	OT5	24"	1"	1"	1"	4"	1"
	OT11,16	24"	1"	1"	1"	9"	1"

Notes:

¹The above are abbreviated model numbers.

²Horizontal units are not approved for attic installation.

All installations and services must be performed by qualified service personnel.

The minimum clearances listed in the preceding table are for fire protection. Clearance for servicing the front of the furnace and the rear of the lowboy models should be at least 24 inches. A clearance of 24 inches is recommended for passage to all points on the furnace requiring service access.

The OH5-11-16 furnaces may be installed on combustible flooring. The OL2-5-11-16-20-33-37-39 and OC2-5 furnaces are to be installed on non-combustible flooring only. A non-combustible floor base is available for the counterflow models OC2-5, which then allows these models to be adapted for installation on combustible flooring (use non-combustible floor base Model No.125 for OC5, Model No 56 for OC2).

NOTE: When power venting a Thermo Pride oil fired furnace with a power venting system other than the system supplied by Thermo Pride, a fiber chamber and an isolated combustion air kit (PVB or Beckett boot) is to be used with the other manufacturers power venting system.

NOTE: On the front flue, lowboy, all highboy or counterflow models, it is possible to rotate the flue elbow (which is factory installed for vertical discharge) 90° counterclockwise from the vertical position to adapt to various venting systems. (See following page for details)

⚠ CAUTION MUST BE TAKEN NOT TO EXCEED 90° ROTATION (OF THE FLUE ELBOW) COUNTERCLOCKWISE OR RIGHT FROM THE VERTICAL POSITION.

ROTATION OF FRONT FLUE ELBOW

When an installation requires that the flue exit out the left hand side casing on a front flue unit, remove screw securing the 90 deg. elbow and rotate it 90° **counterclockwise**. Then, by following dimensions in Table 1, locate the center point for the exit of the flue for the particular size furnace. Once the center has been located, use a scribe to mark the hole size, listed in the chart, which corresponds with the furnace being used. Cut hole out and extend flue through side casing.

A trim collar may be ordered from Thermo Products to hide the gap around the flue pipe. This trim collar, however, is not required for operation.

All installations and services must be performed by qualified service personnel.

NOTE: ROTATION OF FLUE PIPE IS ONLY ALLOWED FOR LEFT HAND SIDE VENTING APPLICATIONS.

TABLE 1: Suggested sizes and positions of flue pipe opening on left hand side of casing.

UNIT	DIA. HOLE	“X” DIM.	“Y” DIM.	FLUE DIA.	TRIM COLLAR/ GASKET PART #
OC2	5-1/2”	3-5/8”	28-3/8”	5”	14121/330073
OC5	6-1/2”	4-3/4”	31-7/16”	6”	14131/330005
OH5	6-1/2”	4-3/4”	33-1/16”	6”	14131/330005
OH11	6-1/2”	4-3/4”	35-1/4”	6”	14131/330005
OH16	7-1/2”	4-5/16”	41-3/8”	7”	14132/330006
OL2*	5-1/2”	3-5/8”	28-5/16”	5”	14121/330073
OL5*	6-1/2”	4-5/8”	34-15/16”	6”	14131/330005
OL11*	6-1/2”	4-1/2”	37-5/8”	6”	14131/330005
OL16*	7-1/2”	4-1/2”	39-1/8”	7”	14132/330006
OL20*	7-1/2”	4-1/2”	43-1/4”	7”	14132/330006

* FRONT FLUE MODELS ONLY

“X” DIMENSION IS MEASURED FROM SEPARATOR PANEL.

“Y” DIMENSION IS MEASURED FROM THE BLOWER PAN ON “H” MODELS AND FROM THE BASE ON “L” AND “C” MODELS.

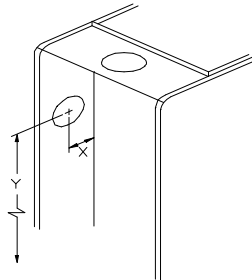

Fig 1: Recommended location for drilling hole to connect vent pipe to the furnace through the left hand side casing.

A. DRAFT REGULATORS:

A draft regulator is supplied with the furnace and should be installed according to the regulator manufacturers recommendations. With the burner operating, use a draft gauge to adjust the regulator to the proper setting. (refer to the instructions enclosed with draft regulator to adjust to the proper setting). When the burner air supply and draft are properly adjusted, the overfire draft should be a negative (-).01" to (-).02" WC, as measured at the 5/16" overfire air tap (See Fig. T). This tap is provided in the upper burner mounting plate. To measure the flue draft, punch a small hole in the vent connector pipe as close to the furnace as possible and always before the draft regulator.

B. DUCT WORK/AIR CONDITIONING:

If the furnace is used in connection with summer air conditioning (cooling), the furnace should be installed parallel with or on the upstream side of the evaporator coil to avoid condensation in the furnace heat exchanger. If the cooling unit is installed with a parallel flow arrangement, dampers or other means used to control flow of air

All installations and services must be performed by qualified service personnel.

should be provided to prevent chilled air from entering the furnace. If such a damper is manually operated, it must be equipped with a means to prevent operation of either unit, unless the damper is in the full heat or cool position.

The duct system should again follow the current design standard of Air Conditioning Contractors of America (ACCA) or ASHRAE Fundamentals volume.

The most common location for the A-shaped coil (A style) is shown in Fig. 2.

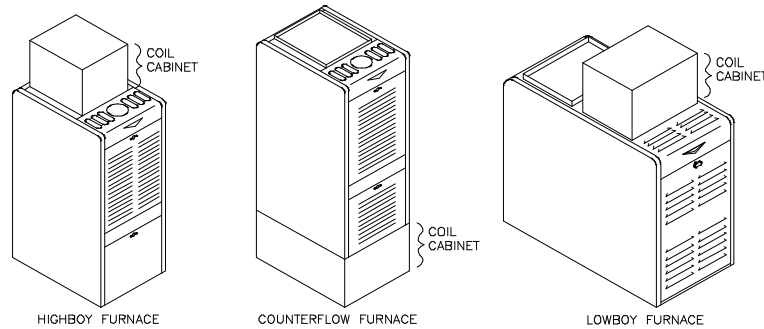

Fig 2: Acceptable locations for the air conditioner evaporator coil.

NOTICE: The minimum coil pan clearance for a sectional or drum type heat exchanger is three inches unless specified otherwise by the individual coil manufacturer.

A slab coil (H-style) is available for the horizontal air flow application on the OT5-11-16 furnaces refer to Fig. 3.

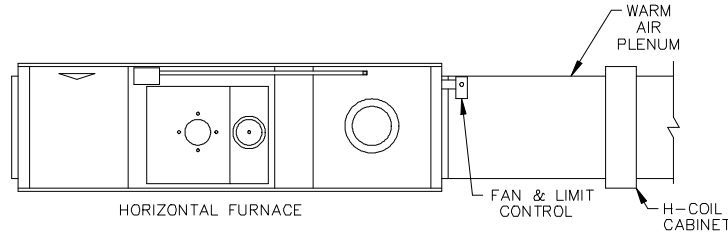

Fig. 3: An acceptable location for the air conditioner evaporator coil when used with a horizontal furnace.

To obtain proper airflow with an air conditioning coil installed on a belt drive unit, the motor and/or blower pulley may need to be changed. On a direct drive unit, the blower motor speed may need to be changed depending upon the size of the air conditioning system installed and the airflow resistance of the duct system.

NOTE: The horizontal units have direct drive blowers and no pulley or motor change is required.

C. FILTERS MOUNTED EXTERNAL TO THE FURNACE:

The filters of the OC2-5 mount in the return air plenum on the top opening on the top of the furnace. (For installation detail, see figure 4).

All installations and services must be performed by qualified service personnel.

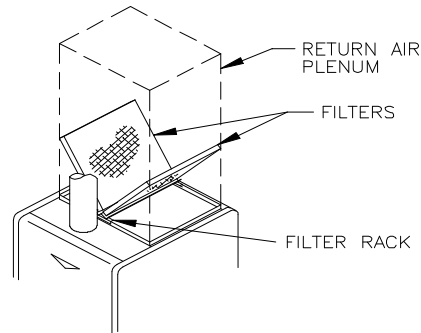

Fig. 4: Air filter mounting location for the OC2-5 furnace.

On **highboy** furnaces, it is necessary to cut the return air opening in the side or rear casing, depending upon the needs of the specific installation.

The filter rack provided with the furnace, refer to Fig. 5, will serve as a template to scribe a mark for the return air opening on the casing. Place the filter rack on the casing one inch up from the bottom of the furnace and centered from side to side. Place the securing flange against the casing when locating the return air opening.

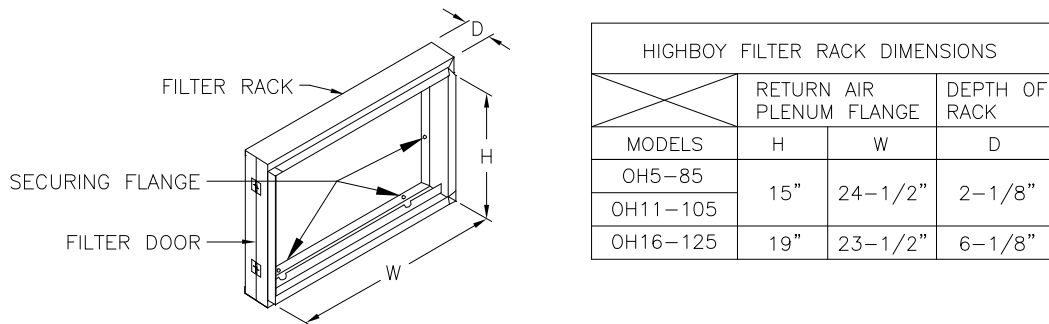

Fig. 5: A typical filter rack and dimensions for the highboy furnaces.

PLEASE NOTE: While scribing the return air opening, the filter rack can be held in position by tape or similar temporary means.

Position the open end of the filter rack so as to provide access for filter replacement. Once the filter rack is positioned correctly, scribe a line along the inside of the securing flange on three of the sides. To scribe a line on the fourth side (the open end), use the open end support as a guide.

Remove the filter rack and cut the return air opening in the casing. Now the filter rack can be anchored to the furnace with screws or pop-rivets through the securing flange of the filter rack.

⚠WARNING: When cutting openings in the casing **DO NOT CUT ANY SUPPORTING CLIPS OR ANGLES.** Cut as close to the scribed line as possible, but do not cut the base clip or blower pan support angle. (See Fig. 6).

All installations and services must be performed by qualified service personnel.

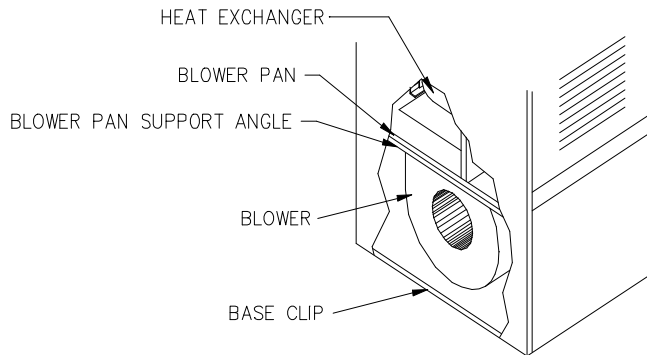

Fig. 6: Cutaway view of fan section of a typical highboy furnace.

Connect the return air plenum to the filter rack and slide the filter into place. Dimensions for adapting the return air plenum to the filter rack are provided on the bottom of the previous page.

D. FAN AND LIMIT POSITION AND LOCATION

⚠WARNING: The predetermined fan and limit locations on all of the Thermo Pride oil fired furnaces have been tested and approved by Thermo Products, LLC. in conjunction with Underwriters Laboratories, Inc. Any attempt to relocate these safety controls or replace these safety controls with a control that is not approved, or is incompatible, may result in personal injury, substantial property damage or death.

The units listed in the table below must have the fan and limit control installed at the time of unit installation. A locating bracket is provided with each of the units below.

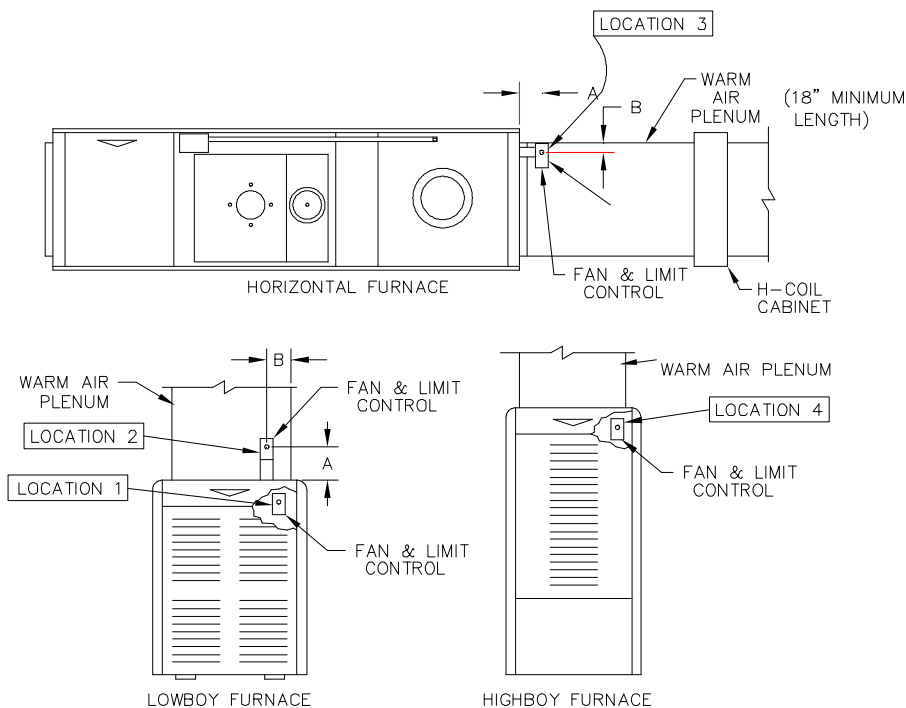

TABLE 2: Installation location of the fan and limit control for each furnace

MODEL	DIM. A	DIM. B	LOCATION
OH5-85	—	—	4
OH11-105	—	—	4
OH16-125	—	—	4
OL2-56	—	—	1
OL5-85	—	—	1
OL11-105	—	—	1
OL16-125	—	—	1
OL20-151	—	—	1
OL33-200	7"	8"	2
OL37-250	7"	6"	2
OL39-320	7"	10-3/4"	2
OT5-85	4-5/16"	4-3/16"	3
OT11-105	7"	2"	3
OT16-125	7"	2"	3

All installations and services must be performed by qualified service personnel.

Fig. 7: Fan and limit location for lowboys, horizontal units and highboys.

FAN & LIMIT LOCATION FOR HORIZONTAL UNITS WITH AIR CONDITIONING COIL:

The fan & limit control should be mounted between the H-coil cabinet and furnace. For distances from top of plenum and furnace, see Fig. 7. **IMPORTANT:** Do not try to mount fan/limit in H-coil cabinet.

NOTE: The OL2 and OC2 only, come standard with an oil filter packaged with the furnace. This filter has the capacity of filtering down to a 10 micron particle. This is to assure the small diameter burner nozzles in the low heating capacity furnaces are installed with a fine filter to help prevent nozzle clogging.

E. BURNER INSTALLATION:

NOTICE: Remove all cardboard packing from around chamber before calling burner.

The oil burner will mount on three stud mounting bolts on the lower mounting plate covering the opening in the front of the heat exchanger. The end of the burner tube should be inserted no further than 1/4 inch back from the inside surface of the combustion chamber. A distance further than 1/4 inch back from the inside chamber wall may cause impingement and sooting.

NOTE: OVERFIRE AIR TAP MAY BE LOCATED ON EITHER SIDE OF FLAME INSPECTION COVER. (See Fig. 8).

TWO PIECE MOUNTING PLATE

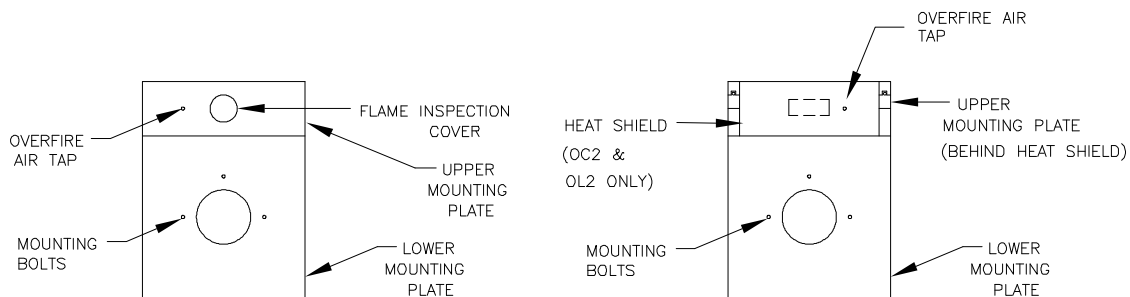

Fig. 8: Typical location of the overfire air tap

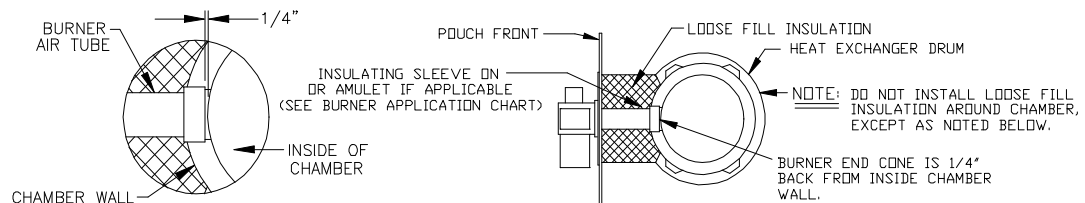

Fig. 9: (Top view) Burner insertion illustration

When mounting the burner, the upper mounting plate (Fig. 8) must be removed to provide access to the area in front of the combustion chamber. The combustion chamber can then be moved forward or backward slightly to allow for adjustment in positioning the burner tube. A fiber insulating sleeve or amulet is provided on the burner tube of specific Thermo Pride burners.(see Fig. 10). See Thermo Pride burner application chart for type of insulator. Do not allow the burner tube or end cone to physically touch or protrude into the chamber, as excess

All installations and services must be performed by qualified service personnel.

heat transfer could result in destruction of the tube, end cone or both. The burner tube/end cone is properly positioned, when the end is ¼ inch back from the inside surface of the combustion chamber wall.

NOTE: The OL2 and OC2 furnace models have two chamber positioning clips on the pouch bottom to prevent the chamber from being pulled forward too close to the mounting plate and burner. If the chamber is pulled back against these clips the insertion depth should be correct. The loose-fill insulation that is included in a brown paper bag should be lightly placed around the burner tube between the front of the combustion chamber and the burner mounting plate. **(DO NOT PACK THE INSULATION DOWN).** The loose-fill insulation should be placed in such a fashion that the surface of the insulation is sloped from the top of the combustion chamber to the top of the lower mounting plate. The purpose of the loose insulation is to help protect the burner tube, mounting plates and vestibule area from excessive temperatures.

On the horizontal units, the loose-fill insulation will fall down around the side of the chamber (the chamber is on its side in horizontal units). This presents no problem to the unit, as the amount of insulation under the side will be minimal, but take care not to allow the insulation to fall into the open end of the chamber where it may burn and blow around, possibly lodging in the burner.

NOTE: Do not place loose insulation around chamber sides and back except for the larger units (Models OL33, 37 and 39) where the loose insulation is to be used around rear of chamber to ensure chamber stability. See larger unit assembly instructions for further details. (See Fig. 9).

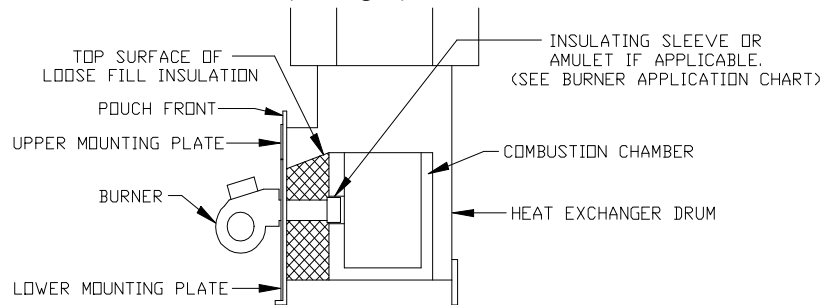

Fig. 10: (Side view) Burner insertion illustration

F. HORIZONTAL FURNACE POSITIONS:

The horizontal furnace may be turned end for end, or rotated, making the top into the bottom, as shown in Fig. 11.

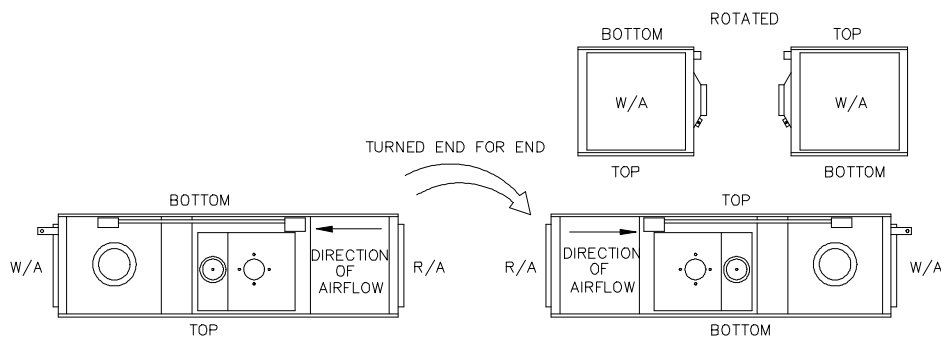
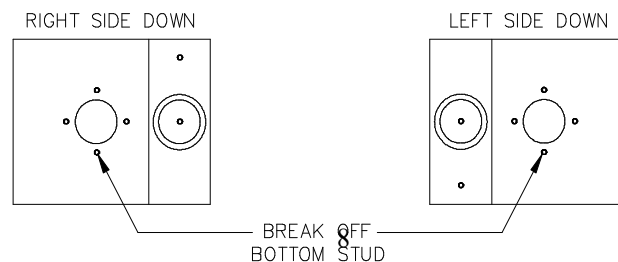

Fig. 11: A horizontal furnace rotated 180° (or flipped end for end) to reverse airflow direction

After the furnace has been positioned, the bottom burner mounting stud must be broken off before mounting the burner (See Fig. 12). Also, the fan & limit and its mounting bracket must be relocated once the unit is in position. (See Fig. 7).



All installations and services must be performed by qualified service personnel.

Fig. 12: Required modification to burner mounting studs before burner installation

G. EXTERNAL WIRE HARNESS LOCATIONS FOR OL33, 37

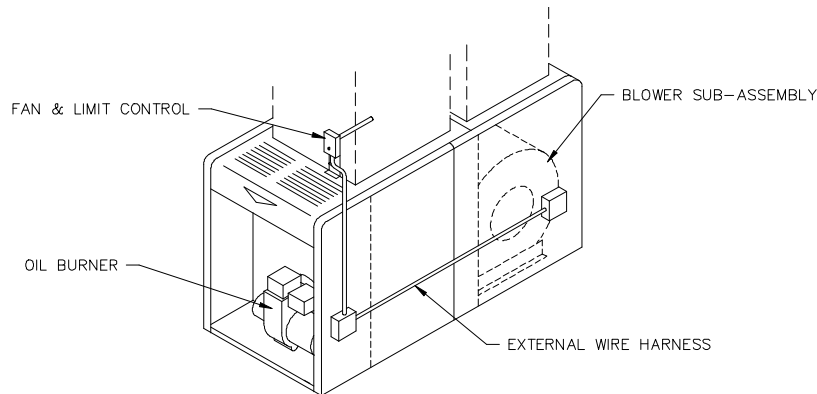

Fig. 13: External electrical wiring in conduit on large furnace models

The OL33, 37 and 39 furnaces have an external wire harness that mounts in pre-punched holes in the side casings (See Fig. 13).

A Horizontal furnace is shown below with external wire harness and fan speed terminal strip (blower access panel removed). (See Fig. 14).

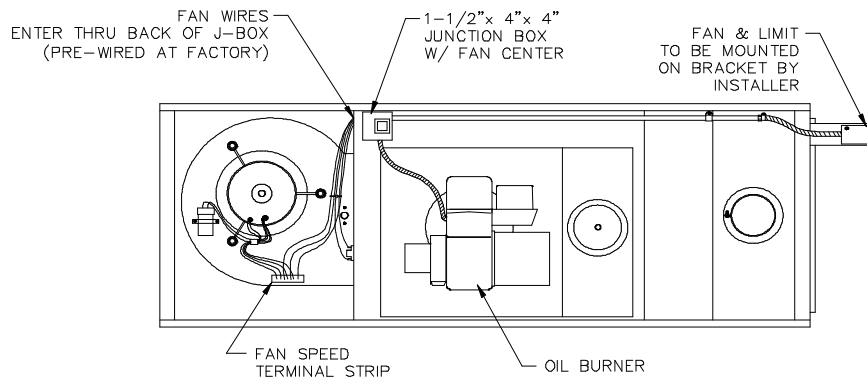

Fig. 14: The wiring system of a typical horizontal furnace

H. BURNER SPECIFICATIONS AND APPLICATIONS

THERMO PRIDE BURNER APPLICATIONS

FURNACE MODEL	THERMO PRIDE'S BURNER SPEC NO.	* INS	BECKETT BURNER MODEL & TUBE LENGTH	HEAD	STATIC PLATE	MAXIMUM NOZZLE SIZE**	STANDARD NOZZLE SIZE	OIL PUMP PRESSURE (PSIG)
OC2-56	TP-1401	N	AFG-3-5/8	FO	3-3/8	0.55X70H	0.50X70H	120
OC5-85	TP-101	S	AF 7-3/4	F3	2-3/4	0.75X80H	0.75X80H	100
OH5-85	TP-101	S	AF 7-3/4	F3	2-3/4	0.75X80H	0.75X80H	100
OH11-105	TP-101	S	AF 7-3/4	F3	2-3/4	0.90X80H	0.90X80H	100
OH11-105	TP-1011	S	AFG 7-3/4	F3	2-3/4	0.90X80H	0.90X80H	100
OH16-125	TP-102	S	AF 7-3/4	F6	2-3/4	1.25X80H	1.10X80H	100
OH16-125	TP-1021	S	AFG7-3/4	F6	2-3/4	1.25X80H	1.10X80H	100
OL2-56	TP-1401	N	AFG 3-5/8	F0	3-3/8	0.55X70H	0.50X70H	120
OL5-85	TP-101	S	AF 7-3/4	F3	2-3/4	0.75X80H	0.75X80H	100
OL5-85	TP-1011	S	AFG 7-3/4	F3	2-3/4	0.75X80H	0.75X80H	100

All installations and services must be performed by qualified service personnel.

OL11-105	TP-101	S	AF 7-3/4	F3	2-3/4	0.90X80H	0.90X80H	100
OL11-105	TP-1011	S	AFG 7-3/4	F3	2-3/4	0.90X80H	0.90X80H	100
OL16-125	TP-102	S	AF 7-3/4	F6	2-3/4	1.25X80H	1.10X80H	100
OL16-125	TP-1021	S	AFG 7-3/4	F6	2-3/4	1.25X80H	1.10X80H	100
OL20-151	TP-1003	S	AF 7-3/4	F12	2-3/4	1.35X80S	1.35X80S	100
OL20-151	TP-1031	S	AFG 7-3/4	F12	2-3/4	1.35X80S	1.35X80S	100
OL33-200	TP-104	S	AF 5-3/4	F22	2-3/4	2.00X80S	1.75X80S	100
OL37-250	TP-105	N	AF 5-3/4	F31	2-3/4	2.50X80S	2.25X80S	100
OL39-320	TP-106	N	AF 5-3/4	F31	SPIDER	3.00X80S	2.75X80S	100
OT5-85	TP-101	S	AF 7-3/4	F3	2-3/4	0.75X80H	0.75X80H	100
OT11-105	TP-101	S	AF 7-3/4	F3	2-3/4	0.90X80H	0.90X80H	100
OT11-105	TP-1011	S	AFG 7-3/4	F3	2-3/4	0.90X80H	0.90X80H	100
OT16-125	TP-102	S	AF 7-3/4	F6	2-3/4	1.25X80H	1.10X80H	100
OT16-125	TP-1021	S	AFG 7-3/4	F6	2-3/4	1.25X80H	1.10X80H	100

* INSULATOR S = SLEEVE OR N = NONE

** MAXIMUM NOZZLE SIZE FOR UL LISTING OF FURNACE. THE NOZZLE SIZE GIVES THE NOMINAL FLOWRATE, IN GPH, FOLLOWED BY THE SPRAY ANGLE, IN DEGREE'S, AND THE SPRAY PATTERN, EITHER "H" FOR HOLLOW CONE OR "S" FOR SOLID CONE. FOR EXAMPLE, A NOZZLE RATED AT 0.65 GPH @ 100 PSIG THAT PROVIDES AN 80° SPRAY ANGLE AND A HOLLOW SPRAY PATTERN WOULD BE ABBREVIATED IN THE TABLE AS "0.65 X 80H".

For more specific burner information, contact Thermo Products, LLC. P.O. Box 237, Denton, NC 27239. Phone 800-476-4328.

STANDARD BURNER NOZZLES: The OL2, OC2 and OC1, along with the OL33, OL37 and OL39 have the nozzles already installed in the burners. The balance of the oil units has the nozzles shipped as loose items with the furnace. Below is a chart showing the heating capacity of the furnace for each approved nozzle size.

OIL NOZZLE CAPACITY CHART			
UNITS	NOZZLE SIZE (GPH)	EQUIVALENT HEAT INPUT RATE* (BTU/HR)	EFFECTIVE HEATING CAPACITY** (BTU/HR)
OL2,OC2	.50	70,000	56,000
	.55	77,000	61,600
OL,OH,OC,OT5	.75	106,250	85,000
OC5	.85	119,000	95,200
OL, OT11	.85	119,000	95,200
	.90	126,000	100,800
OH11	1.00	140,000	112,000
OH,OL,OT16	1.10	154,000	123,200
	1.20	168,000	134,400
	1.25	175,000	140,000
OL20	1.35	189,000	151,200

All installations and services must be performed by qualified service personnel.

OL33	1.75	245,000	196,000
	2.00	280,000	224,000
OL37	2.25	315,000	252,000
	2.50	350,000	280,000
OL39	2.75	385,000	308,000
	3.00	420,000	336,000

All rates shown above achieved with 100 PSIG pump pressure (except for OL2 and OC2, which require 120 PSIG).

* Based on #2 domestic heating fuel oil having heating value of 140,000 BTU per gallon.

** Based on thermal efficiency of 80%.

RIELLO BURNER APPLICATION CHART

The optional F3 and F5 Riello flame retention oil burners have been UL listed (UL File #MP3252) for application on the following Thermo Pride oil fired furnaces.

MODEL PART	OC5, OL5, OH5, OT5	OL11, OH11, OT11	OL16, OH16, OT16	OL20	***OL2
MTG. PLATE PART NO.	35750	35750	35750	35750	UNCHANGED
MTG. PLATE GASKET PART NO.	330088	330088	330088	330088	UNCHANGED
**NOZZLE SIZE	.60-60A*	.75-60A*	.90-60A*	1.10-60A*	.50-60A
NOZZLE PART NO.	380394	380395	380396	380397	380393
OIL PUMP PRESSURE	145 PSI	145PSI	145 PSI	150PSI	125 PSI
BURNER	F3	F5	F5	F5	F3
BURNER PART NO.	380215	380216	380216	380216	380215

* A refers to hollow pattern nozzle

** NOTE: The reason the Riello burner nozzle sizes are smaller than the standard Thermo Pride burner nozzles is that pre-set pump pressures are higher, therefore achieving the same firing rate with a smaller nozzle.

***OL-2 Requires modified front door included in kit.

For more specific burner information, specifications or service information, reference the training manual enclosed with each Riello burner or contact:

Riello Corporation of America,
5 Pond Park Road
Hingham, Massachusetts 02043

All installations and services must be performed by qualified service personnel.

(617) 749-8292

I. HEAT EXCHANGER CLEANING INSTRUCTIONS:

⚠WARNING: THE HEAT EXCHANGER MUST BE CLEANED BY A QUALIFIED SERVICE PERSON.

It is important to inspect and clean the heat exchanger once a year, or as necessary, to remove any build-up of soot. A layer of soot on the inside of the heat exchanger will act as an insulator and reduce heat transfer, resulting in less efficiency.

To clean the heat exchanger, first turn off all power to the unit. Next, remove the access panel (see below and beginning of following page) immediately above the burner (on the horizontal furnace, it will be located to the side of the burner) to gain entry to the clean-out covers, refer to figure 15. **This panel is identified with a label.** Remove clean-out covers, the vent connector pipe to the chimney, the burner, and the burner mounting plates. When removing the clean-out covers, special care must be taken not to damage the gaskets. Should the gaskets separate, crack, break, or be unsuitable for reuse, the gasket must be replaced before reattaching the clean-out covers.

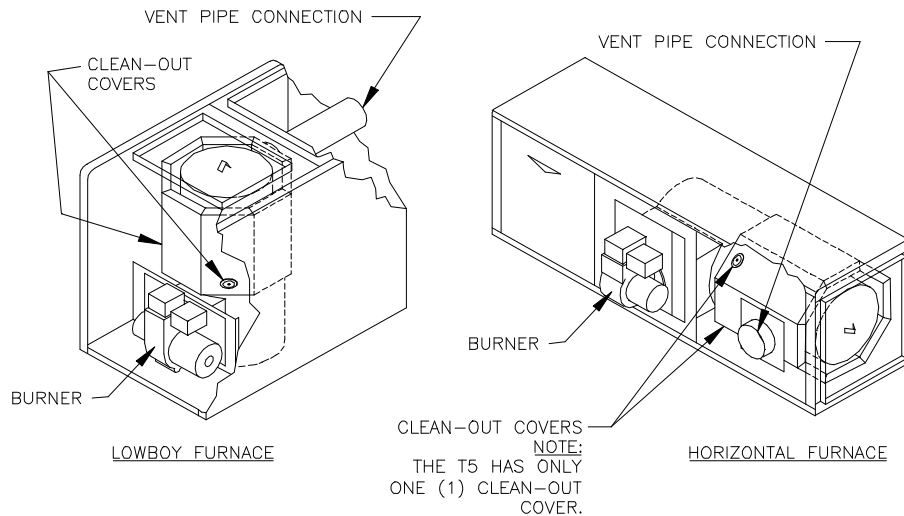
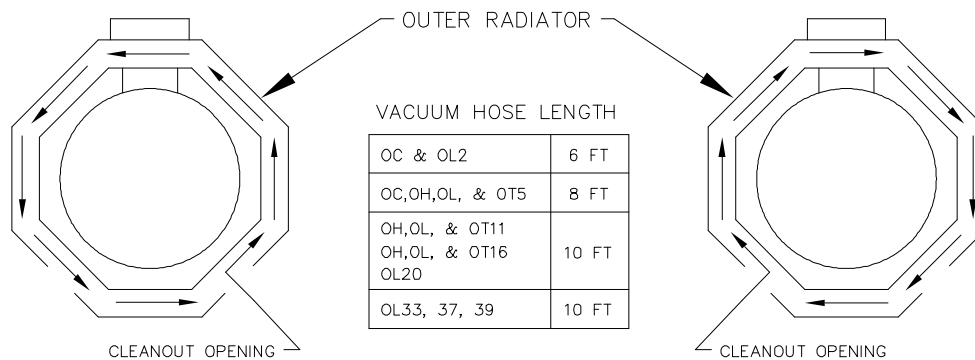

Fig. 15: Typical Heat Exchanger Cleanout Cover Locations.

With access to the inside of the heat exchanger through the burner area, clean-out openings, and vent pipe connection, it is possible to use a long, flexible wire brush and an industrial type vacuum cleaner to remove any soot build-up. **NOTE:** A one inch (outside diameter) vacuum cleaner hose will fit into the radiator.

To vacuum and brush the outer radiator of the heat exchanger, go through the clean-out openings in both directions, as shown in figure 16, below.



All installations and services must be performed by qualified service personnel.

Fig. 16: Recommended method and device for cleaning inside of heat exchanger.

Reassemble the furnace to its original construction. Remount the burner being certain that the air tube is properly inserted into the chamber opening (see section E). If heavy soot deposits were found in the heat exchanger, this may indicate the burner is out of adjustment.

III. USERS INFORMATION SECTION

A. OIL SUPPLY: Do not allow the fuel tank to run completely empty. During the summer, keep the tank full to prevent condensation of moisture on the inside surface of the tank. If the fuel tank runs completely dry, it may be necessary to purge the lines of trapped air. Contact a qualified technician to bleed the lines and restart the burner.

OIL SUPPLY VALVE: Turn the oil supply valve off if the burner is shut down for an extended period of time.

B. COMBUSTION AIR SUPPLY: The burner requires a generous amount of clean combustion air to operate safely. Lack of adequate combustion air can result in erratic operation of the burner, noisy combustion, or fuel odors in the air. NEVER BLOCK THE FURNACE FROM THE SUPPLY OF COMBUSTION AIR. If there is an exhaust fan, dryer or return air grill in the furnace room, there should be increased concern and additional efforts may be required to provide adequate combustion oil to the furnace at all times.

C. INSPECTION AREAS

VESTIBULE: The furnace vestibule area or burner compartment should be inspected by removing the front door of the furnace and looking for signs of excessive heat such as discoloration of components materials damage, from rust or corrosion, soot or carbon build-up.

EXTERIOR OF FURNACE: The furnace exterior should be inspected for signs of excessive heat such as discoloration of materials and damage from rust or corrosion.

FLUE PIPE, VENT PIPE OR CONNECTOR: The furnace vent pipe should be inspected for signs of rust, corrosion pitting or holes in pipe, and leakage around seams in pipe, indicated by soot or condensate streaks.

CHIMNEY OR VENTING SYSTEM: The furnace venting system should be inspected for signs of rust, corrosion pitting or holes, and signs of condensation or moisture leakage from the venting system.

If any of the above symptoms are evident, call a qualified heating contractor for assistance.

⚠CAUTION: DO NOT ATTEMPT TO MAKE REPAIRS YOURSELF!

⚠WARNING: The area around the furnace should be kept free and clear of combustible liquids and material, especially papers and rags.

⚠WARNING: NEVER burn garbage or refuse in your furnace. Never try to ignite oil by tossing burning papers or other material into your furnace.

⚠WARNING: Thermo Pride oil furnaces are designed to burn No. 1 or No. 2 distillate fuel oil. NEVER USE GASOLINE OR A MIXTURE OF OIL AND GASOLINE.

⚠CAUTION: DO NOT ATTEMPT TO START THE BURNER WHEN:

- 1. Excess oil has accumulated,**
- 2. The furnace is full of vapors**
- 3. The combustion chamber is very hot.**

IF ONE OR MORE OF THESE CONDITIONS EXIST, CONTACT A QUALIFIED SERVICE PERSON.

All installations and services must be performed by qualified service personnel.

D. STARTING THE BURNER:

1. Turn the main service switch to "OFF" position.
2. Set thermostat substantially above room temperature.
3. Open shut-off valves in oil supply line to burner.
4. Turn service switch to furnace "ON". If burner starts and runs, but stops again on lockout, it may be necessary to bleed the lines or make burner combustion air adjustments. Contact a qualified service person to adjust and start burner.

E. FILTER CLEANING AND LOCATION:

The air filters should be inspected each month and cleaned when dirty. Cleaning the air filters frequently may reduce airborne contaminants from entering the furnace and depositing in the furnace, duct system and home.

⚠WARNING: To avoid injury from moving parts, hot surfaces, or electrical shock, shut off the power to the furnace before removing any furnace access doors to service the air filters.

OL Series (Lowboy)

To clean a dirty filter, first remove the blower compartment door at the rear of the furnace, refer to figure 17. Remove the dirty filter from the filter rack and clean it with a mild soap and water solution. Make sure filter is thoroughly dry before replacing. Replace the blower compartment door.

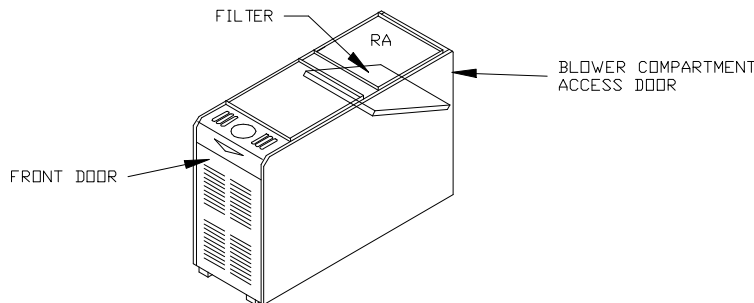

Fig. 17: Location of the air filter and blower compartment access door on the typical lowboy furnace.

OH Series (Highboy)

The filter rack will be located between the return air plenum and the return air opening on the side of the furnace, refer to figure 18. Slide the dirty filter out, clean it with a mild soap and water solution. Make sure filter is thoroughly dry before replacing.

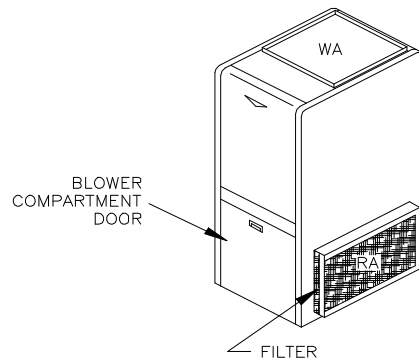

Fig. 18: Location of the air filter on the typical highboy furnace.

OC Series (Counterflow)

All installations and services must be performed by qualified service personnel.

For removal of the filter, remove front door of furnace. Then, remove blower access panel for access to filter, refer to figure 19. Clean filter by vacuuming, tap-water rinsing or washing in an ordinary detergent solution. After cleaning, replace the completely dry filter mesh side down.

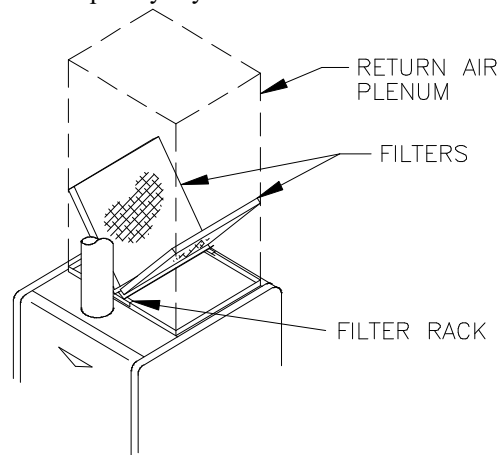

Fig. 19: location of the air filters on a typical counterflow furnace.

All installations and services must be performed by qualified service personnel.

COMBUSTION AND EFFICIENCY TESTING FOR THERMO PRIDE OIL FIRED CENTRAL FURNACES.

Complete this form for each Thermo Pride furnace installed. Read instruction manual carefully before making tests. Retain this form with furnace.

CUSTOMER	NAME				
	ADDRESS				
	CITY, STATE				
HEATING SYSTEM	BURNER MODEL NO.	BLAST TUBE LGTH. INS.	AIR SHUTTER OPENING % OF MAX. (EST)		
	COMBUSTION CHAMBER	CONDITION	MATERIAL	FURNACE MODEL	
	TYPE OF VENTING SYSTEM				
	<input type="checkbox"/> MASONRY CHIMNEY	<input type="checkbox"/> METAL CHIMNEY	<input type="checkbox"/> SIDEWALL POWER VENTER	<input type="checkbox"/> MASONRY CHIMNEY W/INDUCER	
	<input type="checkbox"/> METAL CHIMNEY W/INDUCER	<input type="checkbox"/> MASONRY CHIMNEY W/METAL LINER			
FUEL LINE FILTER	DRAFT CONTROL		FURNACE SERIAL NUMBER		
COMBUSTION TESTS (Operate burner at least 10 minutes before starting tests.)		INITIAL INSTALLATION	SERVICE	SERVICE	SERVICE
	CO2 in stack pipe				
	Draft Over-fire				
	Draft in stack pipe				
	Smoke number				
	Gross stack temp.				
	Furnace room temp.				
	Net stack temp. (Gross stack minus furnace room temp.)				
	Efficiency				
	Nozzle size and spray				
	Oil pump pressure				
	Operation of Controls				
	Burner Safety Controls				
	Check for oil leaks				
	Tests taken by				
	Date				
	NOTES:				
INSTALLER NAME & ADDRESS					

All installations and services must be performed by qualified service personnel.

APPENDIX-A Replacement Parts List

OL2,5,11,16, & 20 REPLACEMENT PARTS LIST

NOTE: REAR FLUE MODEL SHOWN.

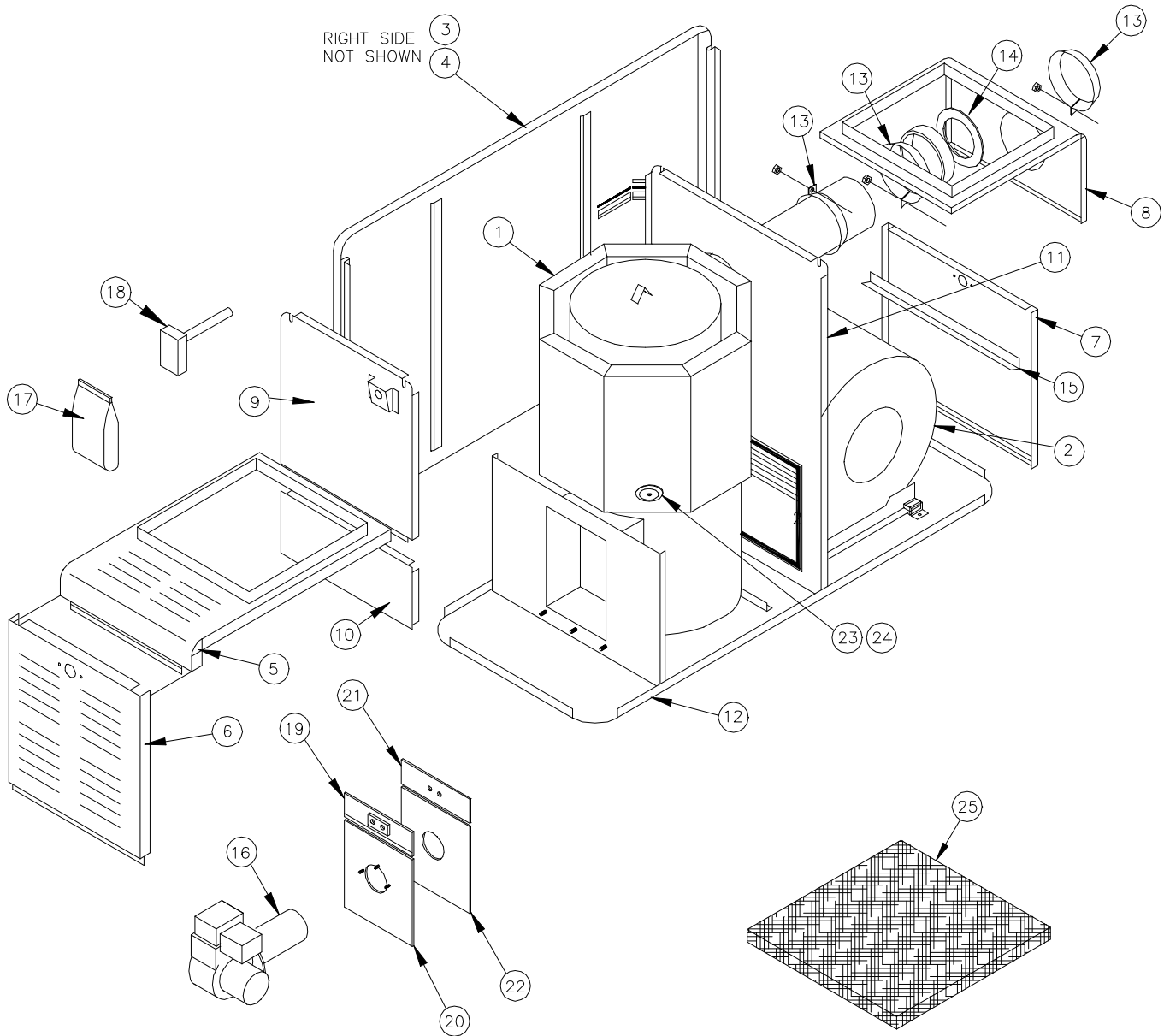

All installations and services must be performed by qualified service personnel.

ITEM	PARTS DESCRIPTION	UNIT	OL2		OL5		OL11		OL16		OL20	
			FRONT FLUE	REAR FLUE	FRONT FLUE	REAR FLUE	FRONT FLUE	REAR FLUE	FRONT FLUE	REAR FLUE	FRONT FLUE	REAR FLUE
1	HEAT EXCHANGER		31449	31448	31459	31458	31471	31470	31486	31485	31501	31500
2	BLOWER ASS'Y DIRECT		S00S4043	S00S4043	S00S4046A	S00S4046A	S00S4046A	S00S4046A	S00S4044	S00S4044	S00S4044	S00S4044
3	SIDE CASING (LEFT)		620000	620000	620002	620002	620004	620006	620008	620008	620010	620010
4	SIDE CASING (RIGHT)		620001	620001	620003	620003	620005	620007	620009	620009	620011	620011
5	TOP FRONT SECTION		610798	610405	620409	620411	620415	620417	620421	620423	620421	620423
6	FRONT DOOR		620400	620400	620407	620407	620413	620413	620419	620419	620425	620425
7	BLOWER ACCESS DOOR		620401	620401	620408	620408	620414	620414	620420	620420	620426	620426
8	TOP REAR SECTION		610404	610406	620410	620412	620416	620418	620422	620424	620422	620424
9	FRONT TOP SEPARATOR		621020	621027	621031	621032	621035	621039	621041	621044	621041	621044
10	FRONT CENTER SEPARATOR		621016	621016	621030	621030	621037	611040	621047	621047	621054	621054
11	REAR SEPARATOR DIRECT		21029	21028	21033	21034	21036	21038	21042	21045	21049	21052
12	BASE DIRECT		20453	20453	20454	20454	20455	20455	20466	20466	20466	20466
13	DRAW COLLAR		14121	14121	14131	14131	14131	14131	14132	14132	14132	14132
14	FLUE COLLAR GASKET		330073	330073	330005	330005	330005	330005	330006	330006	330006	330006
15	REAR FILTER SUPPORT		614710	614710	614715	614715	614715	614715	614726	614726	614726	614726
16	BECKETT OIL BURNER		380204	380204	380737	380737	380737	380737	380738	380738	380739	380739
17	DOOR HANDLE PACKAGE		320152	320152	320152	320152	320152	320152	320152	320152	320152	320152
18	FAN & LIMIT CONTROL		350124	350124	350124	350124	350124	350124	350124	350124	350124	350124
19	TOP MTG PLATE		25708	25708	25716	25716	25716	25716	25716	25716	25716	25716
20	BOTTOM MTG PLATE		25709	25709	25717	25717	25717	25717	25717	25717	25717	25717
21	TOP MTG PLATE GASKET		330070	330070	330055	330055	330055	330055	330055	330055	330055	330055
22	BOTTOM MTG PLATE GASKET		330078	330078	330056	330056	330056	330056	330056	330056	330056	330056
23	CLEAN OUT COVER		11403	11403	11403	11403	11403	11403	11403	11403	11403	11403
24	CLEAN OUT COVER GASKET		330009	330009	330009	330009	330009	330009	330009	330009	330009	330009
25	FILTER		370034 (16 x 20 x 1)	370034 (16 x 20 x 1)	370022 (20 x 20 x 1)	370022 (20 x 20 x 1)	370035 (20 x 25 x 1)	370035 (20 x 25 x 1)	370036 (14 x 25 x 1) (2 REQ'D.)	370036 (14 x 25 x 1) (2 REQ'D.)	370036 (14 x 25 x 1) (2 REQ'D.)	370036 (14 x 25 x 1) (2 REQ'D.)

All installations and services must be performed by qualified service personnel.

OH5,11 & 16 REPLACEMENT PARTS LIST

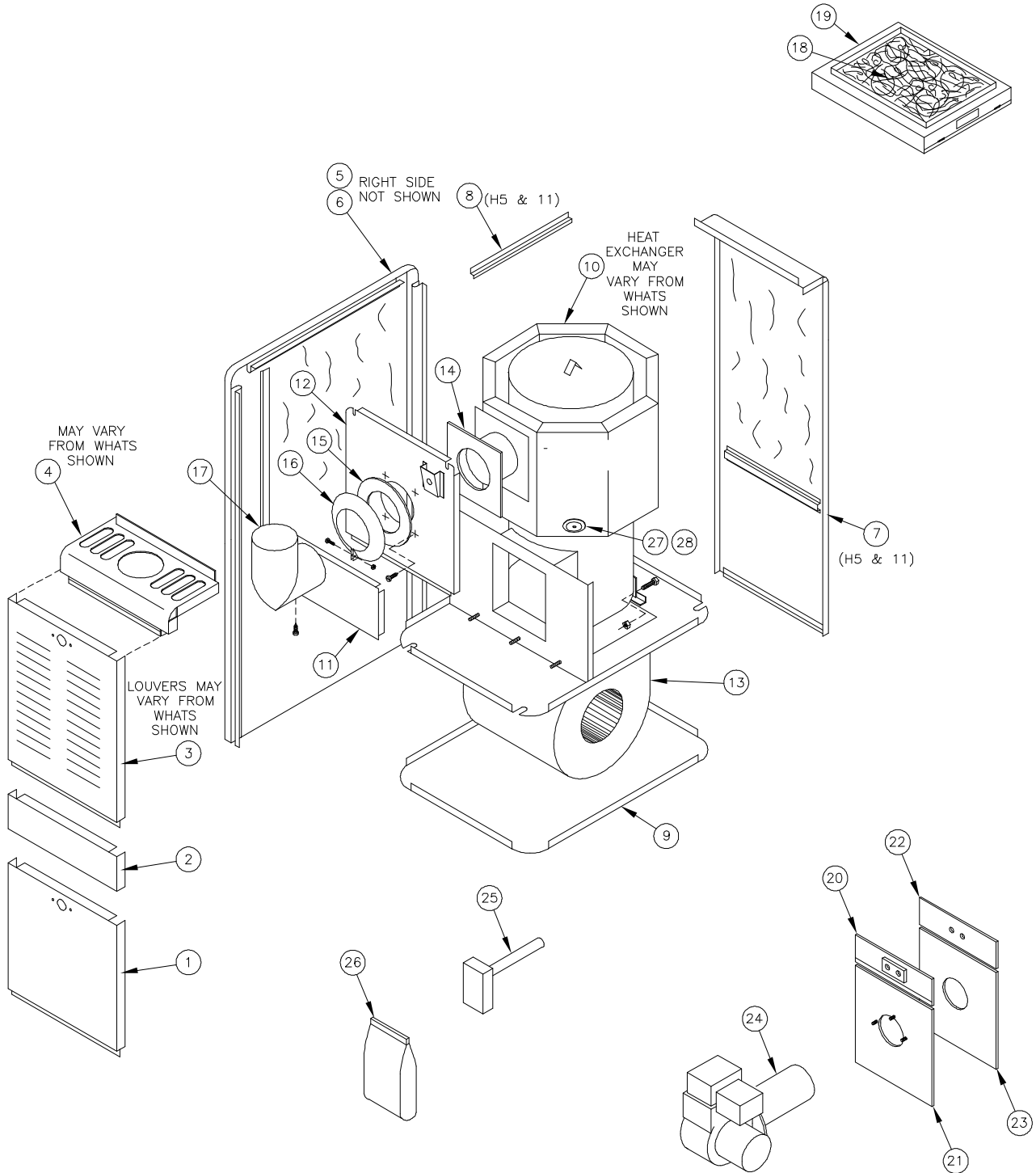

All installations and services must be performed by qualified service personnel.

ITEM	PARTS DESCRIPTION	UNIT		OH5		OH11		OH16	
		PART NO.	QTY.	PART NO.	QTY.	PART NO.	QTY.	PART NO.	QTY.
1	BLOWER ACCESS DOOR			620468	1	620468	1	620746	1
2	FRONT CENTER PANEL			610471	1	610471	1	610749	1
3	FRONT DOOR			620467	1	620473	1	620745	1
4	TOP FRONT SECTION			610799	1	610799	1	610747	1
5	SIDE CASING (LEFT)			620020	1	622022	1	620088	1
6	SIDE CASING (RIGHT)			620021	1	620023	1	620089	1
7	CASING BACK			620471	1	620474	1	(REAR PANEL) 610748	1
8	PLENUM STRIP			613318	2	613318	2	(TOP REAR SECTION) 620750	1
9	BASE			10472	1	10475	1	10751	1
10	HEAT EXCHANGER			31437	1	31580	1	31745	1
11	FRONT CENTER SEPARATOR			621022	1	621080	1	621170	1
12	FRONT TOP SEPARATOR			621077	1	621079	1	621169	1
13	DIRECT DRIVE BLOWER ASS'Y			500S4050	1	500S4050	1	500S4072	1
14	FLUE BACKING PLATE GASKET			330089	1	330008	1	330023	1
15	FLUE COLLAR GASKET			330005	1	330005	1	330006	1
16	DRAW COLLAR			14131	1	14131	1	14132	1
17	ELBOW			35719	1	35719	1	35721	1
18	FILTER			370023 (16x25x1)	1	370023 (16x25x1)	1	370051 (20x25x1)	1
19	FILTER RACK			624750	1	624750	1	624804	1
20	TOP MTG PLATE			25716	1	25716	1	25716	1
21	BOTTOM MTG PLATE			25717	1	25717	1	25717	1
22	TOP MTG PLATE GASKET			330055	1	330055	1	330055	1
23	BOTTOM MTG PLATE GASKET			330056	1	330056	1	330056	1
24	BECKETT OIL BURNER			380230	1	380737	1	380738	1
25	FAN & LIMIT CONTROL			350124	1	350124	1	350124	1
26	DOOR HANDLE PKG			320152	1	320152	1	320152	1
27	CLEAN OUT COVER			11403	2	11403	2	11403	2
28	CLEAN OUT COVER GASKET			330009	2	330009	2	330009	2

All installations and services must be performed by qualified service personnel.

OT5,11, & 16 REPLACEMENT PARTS LIST
(FRONT FLUE SHOWN)

NOTE:
UNIT IS SHOWN IN A VERTICAL POSITION.

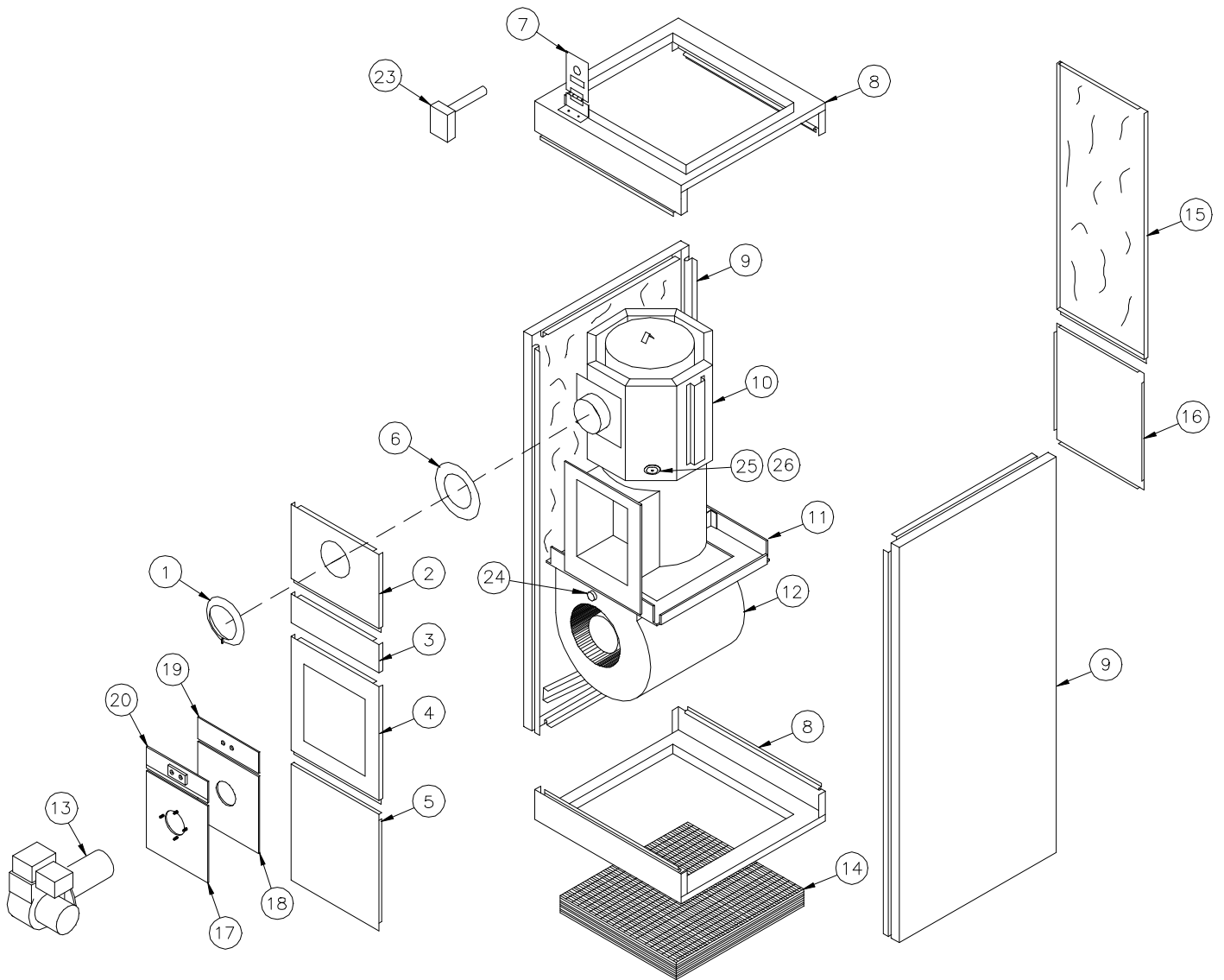

All installations and services must be performed by qualified service personnel.

ITEM #	PART DESCRIPTION \ UNIT	OT5		OT11		OT16	
		FRONT FLUE	REAR FLUE	FRONT FLUE	REAR FLUE	FRONT FLUE	REAR FLUE
1	DRAW COLLAR	14131	14131	14131	14131	14132	14132
2	FRONT TOP PANEL	610495	610497	610504	610506	610513	610515
3	FRONT REMOVABLE PANEL	610493	610493	610502	610502	610511	610511
4	FRONT CENTER PANEL	610492	610492	610501	610501	610510	610510
5	BLOWER ACCESS DOOR	620491	620491	620500	620500	620509	620509
6	FLUE GASKET	330005	330005	330005	330005	330006	330006
7	FAN/LIMIT MTG. HINGE	624146	624146	624136	624136	624136	624136
8	END CAPS (INTAKE & EXHAUST)	620490	620490	620499	620499	620508	620508
9	SIDE CASINGS (RIGHT & LEFT)	620030	620030	620049	620049	620032	620032
10	HEAT EXCHANGER ASSEMBLY	31587	31588	31598	31599	31601	31602
11	BLOWER PAN	21082	21082	21083	21083	21084	21084
12	BLOWER ASSEMBLY	S00S4008	S00S4008	S00S4012	S00S4012	S00S4017	S00S4017
13	BECKETT OIL BURNER	380230	380230	380737	380737	380738	380738
14	FILTER	370050 (16x25x1)	370050 (16x25x1)	370051 (20x25x1)	370051 (20x25x1)	370051 (20x25x1)	370051 (20x25x1)
15	REAR TOP PANEL	610496	610498	610505	610507	610514	610516
16	REAR BOTTOM PANEL	610494	610494	610503	610503	610512	610512
17	BOTTOM MTG. PLATE	25737	25737	25737	25737	25737	25737
18	BOTTOM MTG. PLATE GASKET	330056	330056	330056	330056	330056	330056
19	TOP MTG. PLATE GASKET	330055	330055	330055	330055	330055	330055
20	TOP MTG. PLATE	25716	25716	25716	25716	25716	25716
21							
22							
23	FAN & LIMIT CONTROL	350124	350124	350124	350124	350124	350124
24	AUX CONTROL	350163	350163	350163	350163	350163	350163
25	CLEAN OUT COVER	11403	11403	11403	11403	11403	11403
26	CLEAN OUT COVER GASKET	330009	330009	330009	330009	330009	330009

All installations and services must be performed by qualified service personnel.

OC2 & 5 REPLACEMENT PARTS LIST

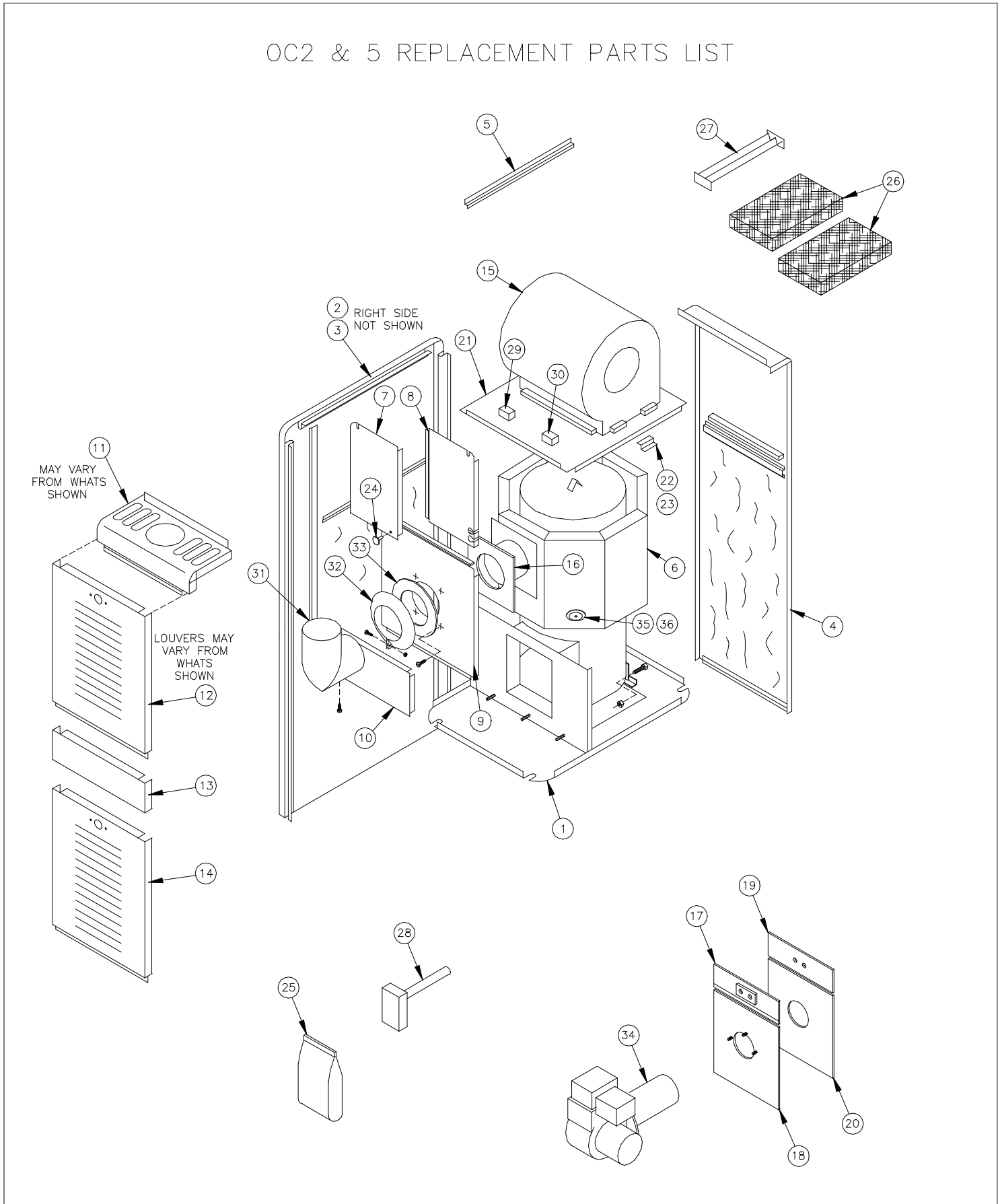

All installations and services must be performed by qualified service personnel.

ITEM	UNIT PARTS DESCRIPTION	OC2		OC5	
		PART NO.	QTY.	PART NO.	QTY.
1	BASE	620486	1	620489	1
2	SIDE CASING (LEFT)	620026	1	620028	1
3	SIDE CASING (RIGHT)	620027	1	620029	1
4	CASING BACK	620485	1	620594	1
5	PLENUM STRIP	613312	2	613318	2
6	HEAT EXCHANGER	31419	1	31436	1
7	BLOWER ACCESS PANEL (LEFT)	611018	1	611024	1
8	BLOWER ACCESS PANEL (RIGHT)	611019	1	611025	1
9	FRONT TOP SEPARATOR	611015	1	611021	1
10	FRONT CENTER SEPARATOR	621016	1	621022	1
11	TOP FRONT SECTION	620403	1	620528	1
12	BLOWER ACCESS DOOR	620484	1	620488	1
13	FRONT CENTER PANEL	610451	1	610471	1
14	FRONT DOOR	620483	1	620487	1
15	DIRECT DRIVE BLOWER ASS'Y	S00S4052	1	S00S4053	1
16	FLUE BACKING PLATE GASKET	330071	1	330089	1
17	TOP MTG PLATE	25708	1	25716	1
18	BOTTOM MTG PLATE	25709	1	25717	1
19	TOP MTG PLATE GASKET	330070	1	330055	1
20	BOTTOM MTG PLATE GASKET	330078	1	330056	1
21	BLOWER PAN	21017	1	21023	1
22	BLOWER HOLD DOWN (RIGHT)	14114	1	14114	1
23	BLOWER HOLD DOWN (LEFT)	14113	1	14113	1
24	CHROME KNOB	320145	1	320145	1
25	DOOR HANDLE PKG	320152		320152	1
26	FILTER	370040 (10 x 17 x 1)	2	370037 (12 x 20 x 1)	2
27	FILTER RACK	624703	1	624705	1
28	FAN & LIMIT CONTROL	350124	1	350131	1
29	AUX FAN CONTROL	350125	1	350125	1
30	AUX LIMIT CONTROL	350126	1	350126	1
31	ELBOW	35714	1	35719	1
32	DRAW COLLAR	14121	1	14131	1
33	FLUE COLLAR GASKET	330073	1	330005	1
34	BECKETT OIL BURNER	380204	1	380230	1
35	CLEAN OUT COVER	11403	2	11403	2
36	CLEAN OUT COVER GASKET	330009	2	330009	2

All installations and services must be performed by qualified service personnel.

OL33, 37 & 39 REPLACEMENT PARTS LIST (FRONT FLUE SHOWN)

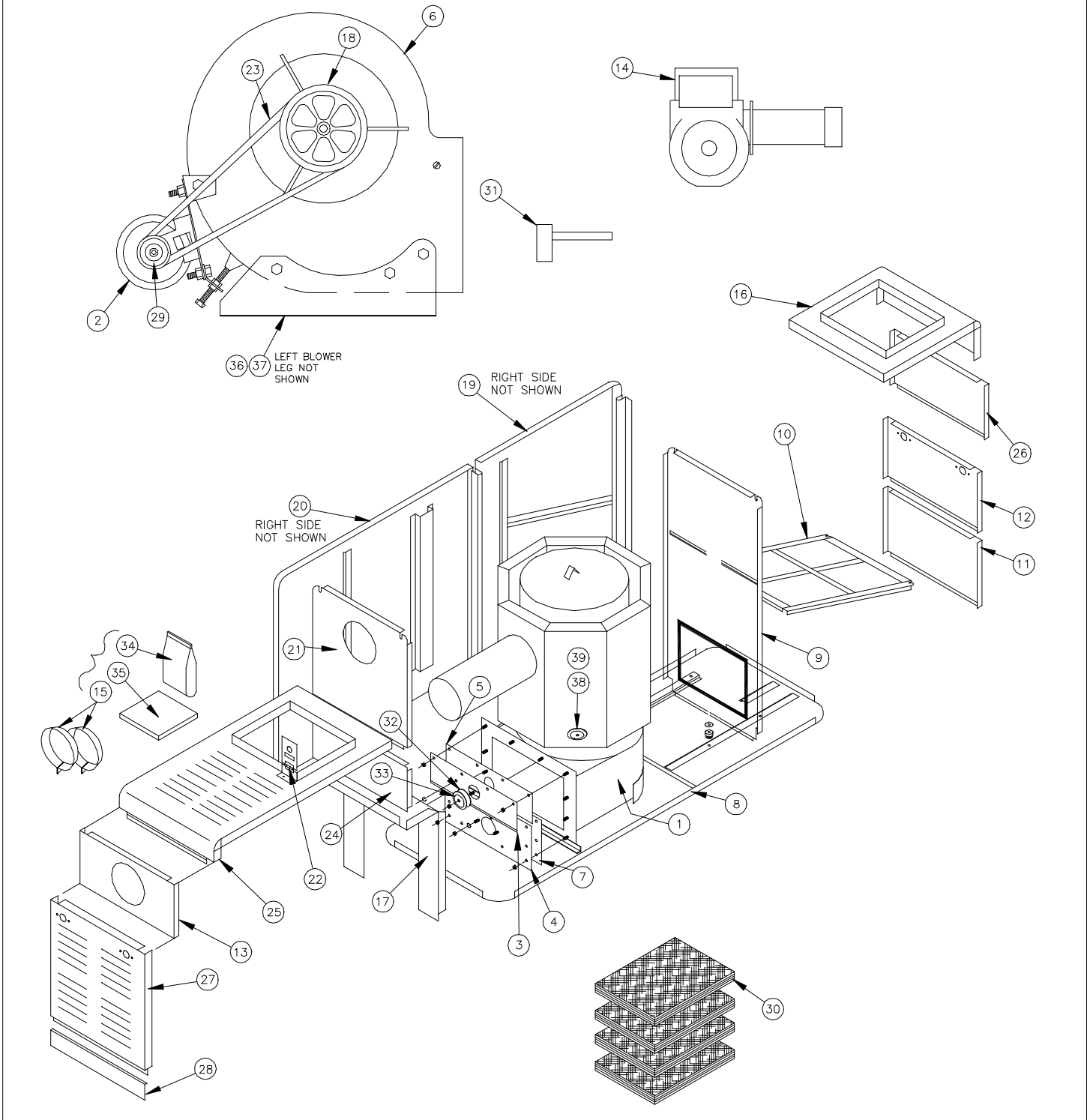

All installations and services must be performed by qualified service personnel.

ITEM #	UNIT		OL33		OL37		OL39	
			FRONT FLUE	REAR FLUE	FRONT FLUE	REAR FLUE	FRONT FLUE	REAR FLUE
1	HEAT EXCHANGER ASSEMBLY		31517	31516	31558	31560	31558	31560
2	BLOWER MOTOR		350302	350302	350305	350305	350306	350306
3	TOP BURNER MTG. PLATE		25726	25726	25732	25732	25732	25732
4	BOTTOM BURNER MTG. PLATE		25727	25727	25733	25733	25733	25733
5	TOP BURNER MTG. PLATE GASKET		330091	330091	330093	330093	330093	330093
6	BLOWER		340010	340010	340011	340011	340011	340011
7	BOTTOM BURNER MTG. PLATE GASKET		330092	330092	330094	330094	330094	330094
8	BASE		30457	30457	30458	30458	30458	30458
9	REAR SEPARATOR		21058	21061	21067	21070	21067	21070
10	FILTER RACK ASSEMBLY		24732	24732	24739	24739	24739	24739
11	REAR BOTTOM PANEL		620436	620436	620442	620442	620442	620442
12	BLOWER ACCESS DOOR		620432	620432	620444	620444	620444	620444
13	TOP FRONT PANEL		610437	610438	610445	610446	610445	610446
14	BECKETT OIL BURNER		380233	380233	380234	380234	380235	380235
15	DRAW COLLAR		624135	624135	624135	624135	624135	624135
16	TOP REAR SECTION		620433	620433	620440	620440	620440	620440
17	FRONT BOTTOM SEPARATOR		621055	621055	621064	621064	621064	621064
18	BLOWER PULLY		340209	340209	340209	340209	340208	340208
19	SIDE CASING REAR	LEFT	620014	620014	620053	620053	620053	620053
		RIGHT	620015	620015	620054	620054	620054	620054
20	SIDE CASING FRONT	LEFT	620012	620012	620051	620051	620051	620051
		RIGHT	620013	620013	620052	620052	620052	620052
21	FRONT TOP SEPARATOR		611056	611059	611065	611068	611065	611068
22	FAN & LIMIT BRACKET		624136	624136	624136	624136	624136	624136
23	BELT		340112	340112	340121	340121	340115	340115
24	FRONT CENTER SEPARATOR		611057	611057	611066	611066	611066	611066
25	TOP FRONT SECTION		620434	620434	620439	620439	620439	620439
26	TOP PANEL REAR		610438	610438	610446	610446	610446	610446
27	FRONT DOOR		620431	620431	620443	620443	620443	620443
28	FRONT BOTTOM PANEL		620435	620435	620441	620441	620441	620441
29	MOTOR PULLY		340201	340201	340202	340202	340202	340202
30	FILTER		—	—	370012 (16x20x2) 4 REQ'D.	370012 (16x20x2) 4 REQ'D.	370012 (16x20x2) 4 REQ'D.	370012 (16x20x2) 4 REQ'D.
31	FAN & LIMIT		350124	350124	350124	350124	350124	350124
32	CLEANOUT COVER GASKET		330009	330009	330009	330009	330009	330009
33	CLEANOUT COVER		15796	15796	15796	15796	15796	15796
34	PARTS PACKAGE		AOPS7566	AOPS7566	AOPS7566	AOPS7566	AOPS7566	AOPS7566
35	GASKET PACKAGE		AOPS7569	AOPS7568	AOPS7565	AOPS7564	AOPS7565	AOPS7564
36	LEFT BLOWER LEG		14245	14245	14260	14260	14260	14260
37	RIGHT BLOWER LEG		14245	14245	14260	14260	14260	14260
38	CLEAN OUT COVER		11403	11403	11403	11403	11403	11403
39	CLEAN OUT COVER GASKET		330009	330009	330009	330009	330009	330009

All installations and services must be performed by qualified service personnel.

APPENDIX-B Wiring Diagrams

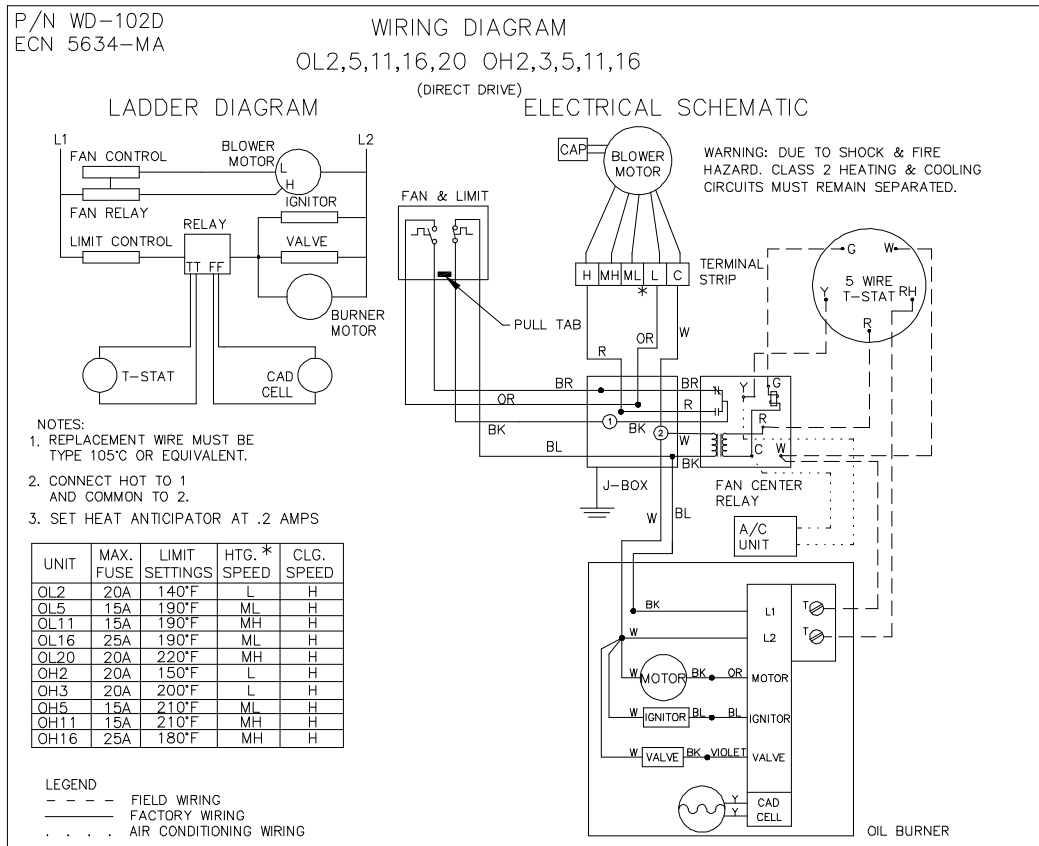
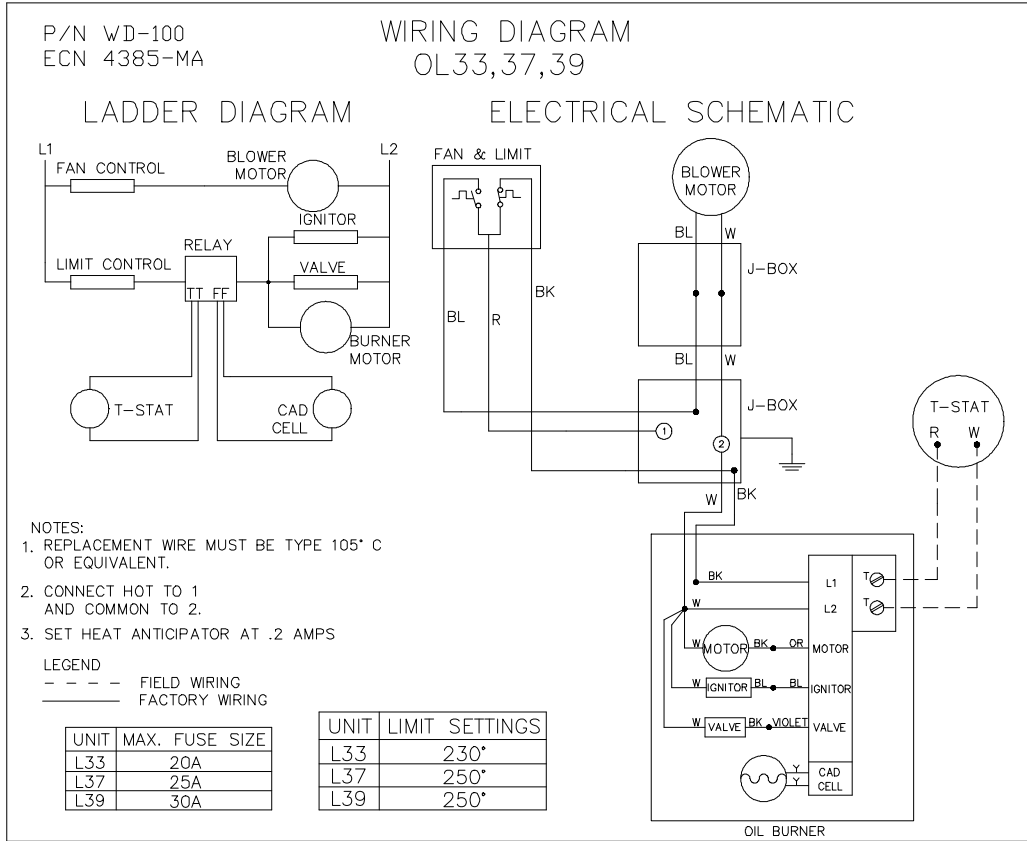

All installations and services must be performed by qualified service personnel.

